

**GROUND INSTALLATION**

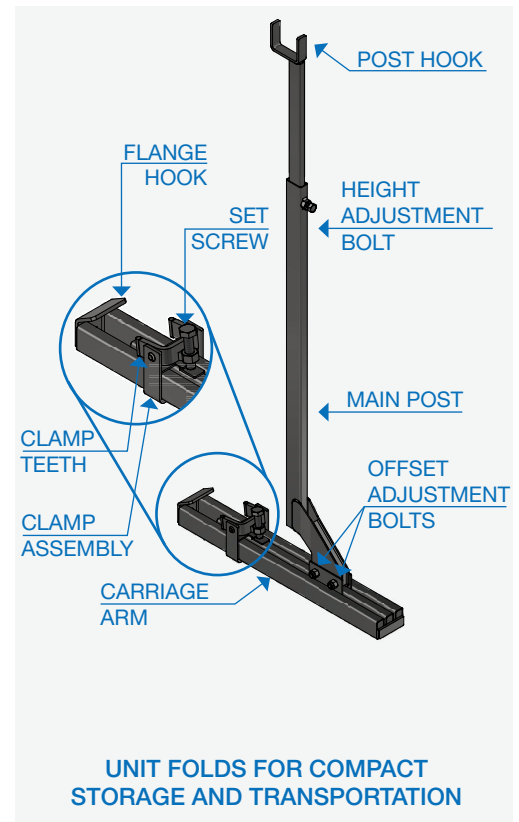
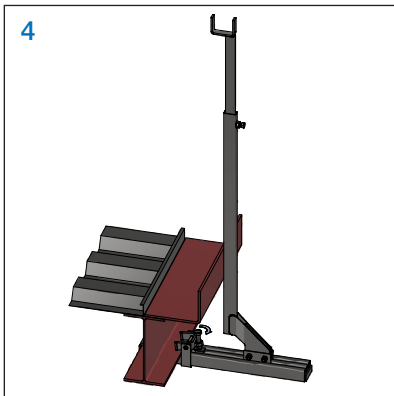
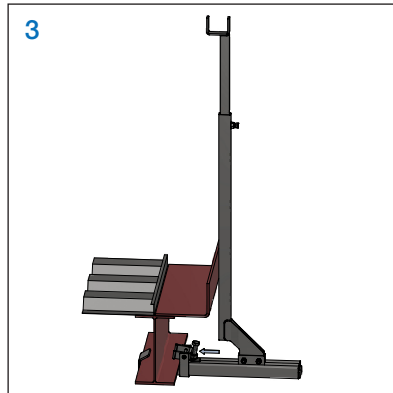
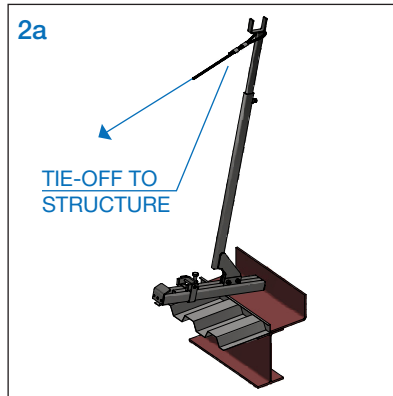
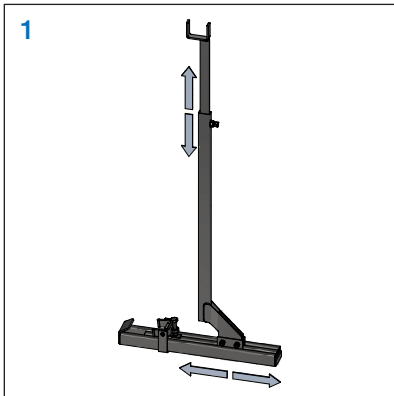

**STEP 1**

Adjust the post height and offset to suit the leading edge geometry. Loosen the adjustment bolts, slide the post to the desired height and offset position. Re-tighten the bolts to prevent further movement.

**STEP 2**

If installing the Beam Clamp at heights, ensure it is securely tethered to the existing structure. Guide the Flange Hook onto the inside beam flange by hooking it over the flange and rotating the Beam Clamp level to secure in place.

**STEP 3**

Slide the Clamp Assembly until it is flush to the outer beam flange with the Clamp Teeth above the flange.

**STEP 4**

Tighten the Clamp Assembly Set Screw until the Clamp Teeth are firmly secured to the beam flange.

## RAILINGS

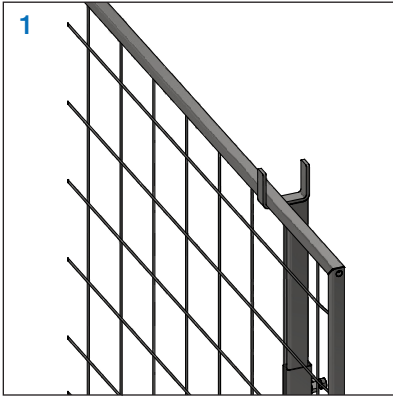

### STEP 1

Connect the Speed Fence to the Guard Holder as per the Speed Fence installation instructions.

When all the steps are completed, the Beam Clamp is ready for the Speed Fence to be installed

Maximum spacing of Beam Clamps not to exceed 9' (2743 mm)

WEIGHT: 27 lbs / 12.2 kg

**ALWAYS REFER TO GENERAL SAFETY NOTES BEFORE INSTALLATION**

***SPEED*  *EDGE***

**FOR TECHNICAL ASSISTANCE:**

info@speededge.ca

905-857-9888

speededge.ca