

INSTALLATION

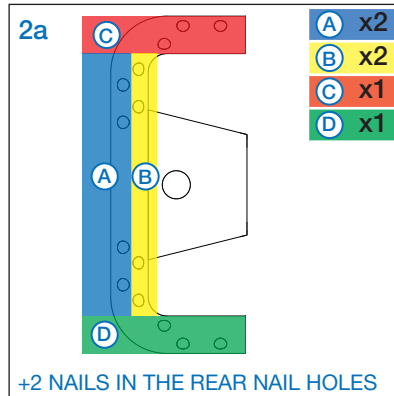
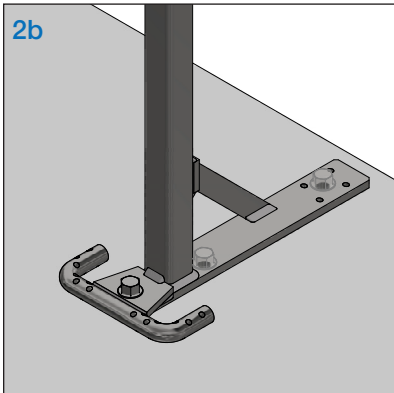
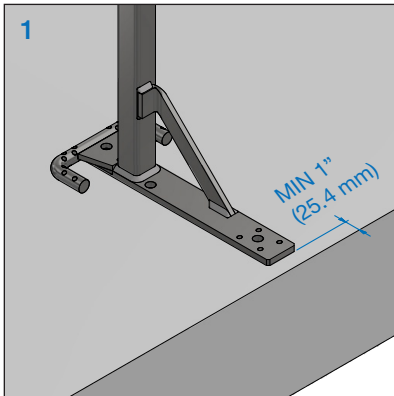

ANCHOR OPTIONS:

- Hilti Quick Bolt 3
- Red Head True Bolt
- Powers Power Stud
- Powers Wedge Bolt

ANCHOR SIZE:

- 3/8" (9.5 mm) diameter by 3 1/2" (89 mm) long anchor with a minimum embedment of 3" (75 mm)

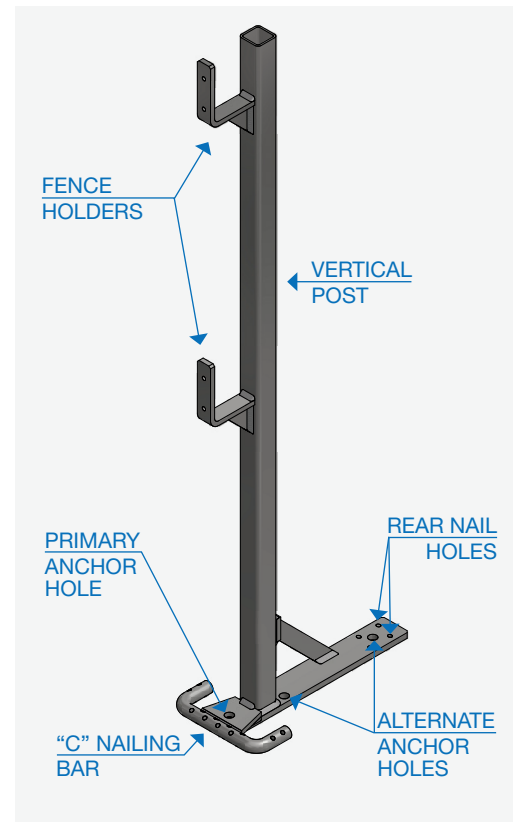

STEP 1

Orient the Shark Stand with the "C" Nailing Bar facing away from the leading edge. Ensure the Shark Stand is located at least 1" (25.4 mm) away from the leading edge.

STEP 2

2A) FASTENING TO 3/4" (19.1 mm) PLYWOOD:

Follow the nailing diagram above for placement and quantity of nails.

Nail a minimum of two (2) 3 1/2" common nails into the front of the "C" Nailing Bar (Zone A - Blue).

Nail a minimum of two (2) 3 1/2" common nails into the back of the "C" Nailing Bar (Zone B - Yellow)

Nail a minimum of one (1) 3 1/2" common nail into each of the sides of the "C" Nailing Bar (Zone C & D - Red & Green)

Nail a minimum of two (2) 3 1/2" common nails into the Rear Nail Holes.

(Alternatively, 3 1/2" common nails can be substituted for #8 x 2" long wood screws; quantity and placement remain the same)

2B) FASTENING TO CONCRETE:

Mark the anchor hole locations.

One (1) anchor required when using the primary anchor hole

Two (2) anchors required when using the alternate anchor holes.

Drill and anchor the Shark Stand with approved anchor(s) as noted.

RAILINGS

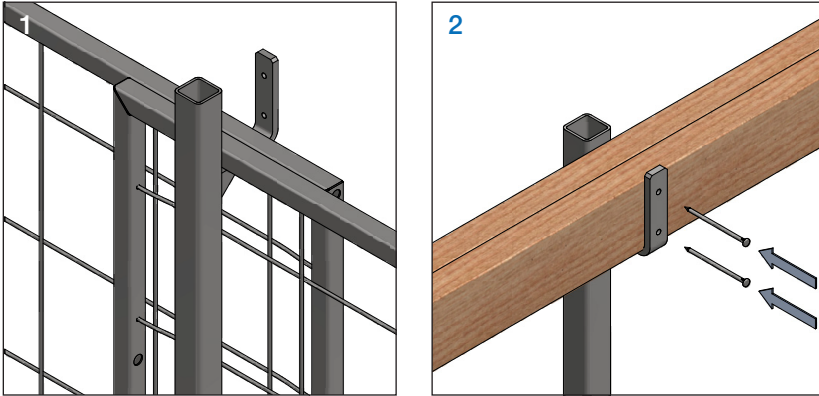

When all the steps are completed, the Shark Stand is ready for the Speed Fence or temporary guardrail to be installed

Maximum spacing of Shark Stand not to exceed 9' (2743 mm)

WEIGHT: 15 lbs / 6.7 kg

STEP 1

Connect the Speed Fence to the Fence Holder as per the Speed Fence installation instructions.

STEP 2

Slide 2 x 4 (38 mm x 89 mm) lumber through the Fence Holders and nail with (2) 2 1/2" long common nails.

ALWAYS REFER TO GENERAL SAFETY NOTES BEFORE INSTALLATION

SPEED  **EDGE**

FOR TECHNICAL ASSISTANCE:

info@speededge.ca

905-857-9888

speededge.ca