



SPEED  ***EDGE***

**SPEED EDGE™
PROTECTION PRODUCTS**

**INSTRUCTION
MANUAL**

www.speededge.ca

SPEED **EDGE** INSTALLATION INSTRUCTIONS

- 1 At all times, workers must use proper fall protection equipment meeting the requirements of all local occupational health and safety legislation and any relevant regulations.
- 2 Installers shall wear proper personal protective equipment (PPE) in compliance with company and site-specific policies and procedures.
- 3 Speed Edge components are never to be used as fall protection anchorages.
- 4 Always follow the Instruction Manual when installing and dismantling of any Speed Edge products. Speed Edge products are not to be installed with or connected to any products not specified in this manual.
- 5 Prior to installation:
 - Ensure all product components are assembled, complete, and not visibly damaged or deformed.
 - All installations on concrete require a minimum compressive strength of 20 MPa. Confirm strength prior to installing any equipment.
 - All installations on plywood require that the plywood structure is not damaged and is capable of supporting any imposed loads caused by the edge protection systems.
- 6 Any installation that differs from the conditions noted in this Instruction Manual requires the review and approval by Speed Edge prior to installation. Contact your Speed Edge representative if your installation differs from this manual.
- 7 Store and transport the equipment in its original packaging and keep it in a dry and clean area.
- 8 When installing or dismantling Speed Edge equipment near a leading edge, ensure it is properly tethered until it is fully installed and secured.
- 9 Always use fasteners noted in the Instruction Manual. For additional fastener options, please contact your Speed Edge representative.
- 10 Always adhere to the capacities and span limits Speed Edge products. Speed Edge cannot certify the safety and use of products not installed in compliance with this manual.
- 11 Speed Edge products are designed for temporary use on active construction sites. Speed Edge products are not to be used under any other conditions.

Speed Edge disclaims liability for all uses of Speed Edge products not explicitly described in this Instruction Manual. Uses not described in this manual must be reviewed and approved by Speed Edge prior to installation. Contact us if you have any questions at info@speededge.com or 905-857-9888.



FOR TECHNICAL ASSISTANCE:

info@speededge.ca
905-857-9888
speededge.ca

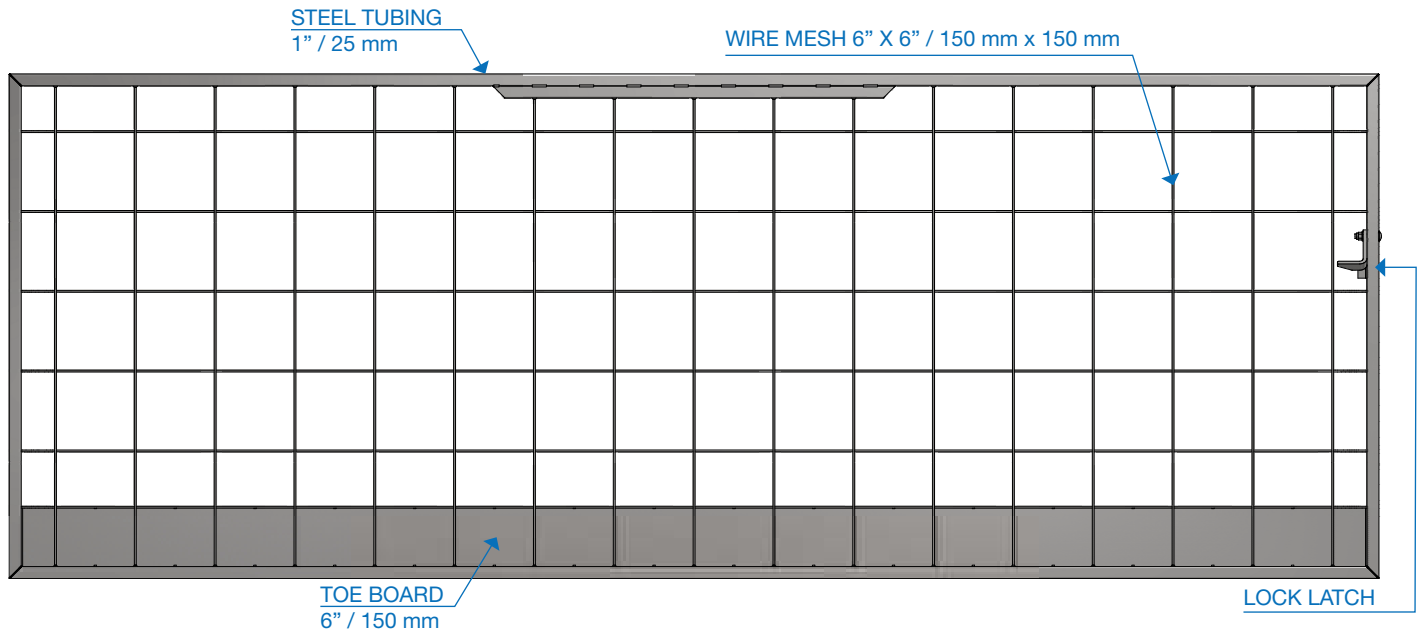

INSTALLATION

Maximum spacing of KF542 not to exceed 4'3" (1500 mm)

Maximum spacing of KF9642 not to exceed 9" (2743 mm)

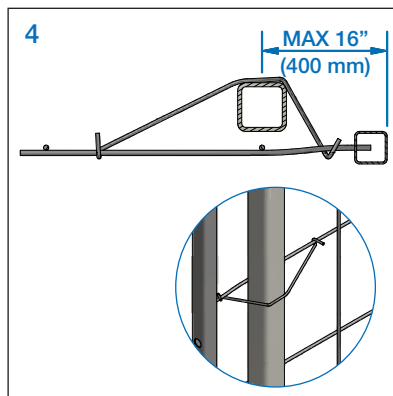
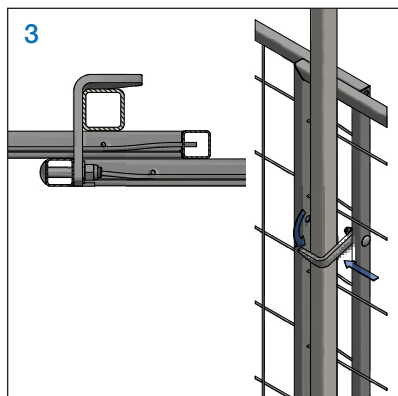
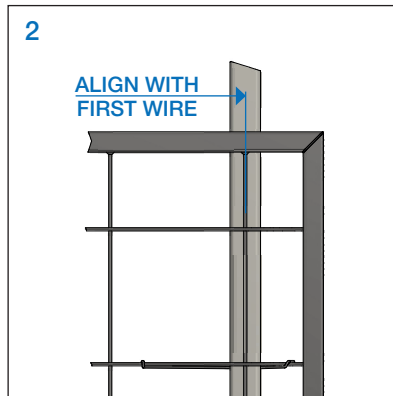
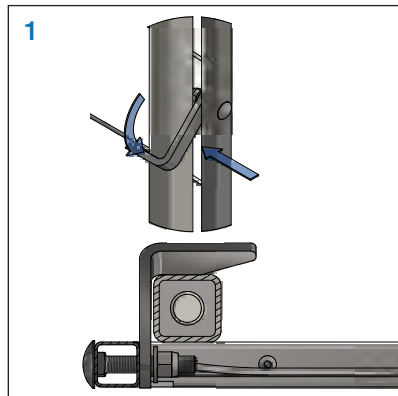

STEP 1

Open the lock latch 90° to the Speed Fence and slide the Speed Fence against the post. Press down on the lock latch so that the Speed Fence is secured against the post.

STEP 2

Install the second post to the right side of the Speed Fence. Line up the post with the first vertical mesh wire of the Speed Fence mesh.

STEP 3

Repeat Steps 1 and 2. The lock latch must pass through the mesh of the first Speed Fence and sit against the second post.

Press down on the lock latch to secure both Speed Fences to the second post and repeat as many times as required and ensure proper overlap.

STEP 4

The last post must be within 16" (400 mm) from the end of the last Speed Fence. To secure the Speed Fence to the last post, install Speed Wire or tie wire.

If a post cannot be secured with a Lock Latch, the post must be secured per the "Engineered & Approved Fence Connection Types".

CORNER INSTALLATION

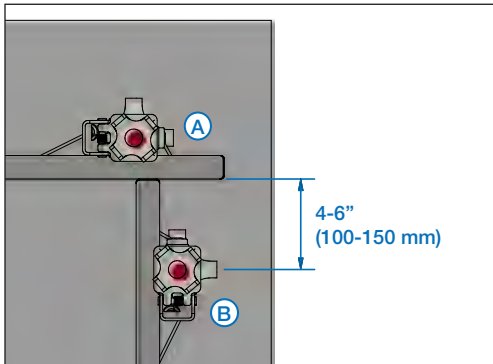
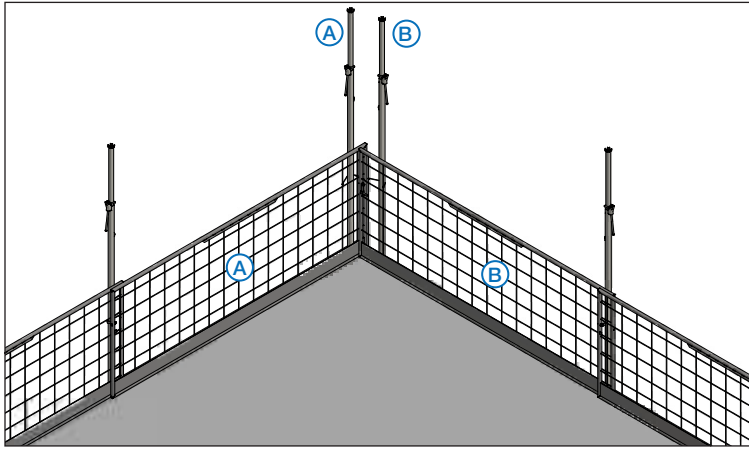

STEP 1

Install the corner post "A" per Speed Post installation instructions.

Verify that the Speed Fence "A" extends beyond the last post per typical fence installation.

STEP 2

Install corner post "B" 4-6" (100-150 mm) from the face of Speed Fence "A".

STEP 3

Install Speed Fence "B" and butt end flush to Speed Fence "A" as shown.

STEP 4

To secure the Speed Fence to the last post, install Speed Wire or tie wire per the "Engineered & Approved Fence Connection Types".

STEP 5

Continue Speed Fence installation as per Speed Fence Instructions.

DOUBLE HEIGHT ARRANGEMENT

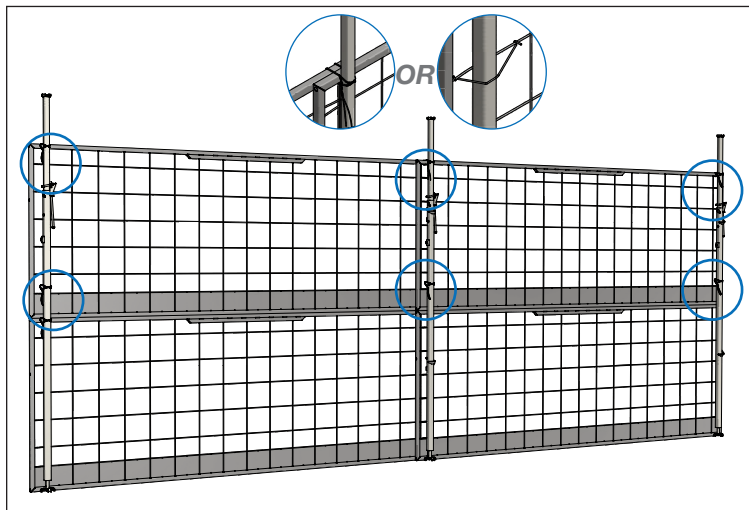

STEP 1

Double height Speed Fence arrangement can only be installed with the Speed Post and the High Post.

STEP 2

Install the Speed Fence as per the installation instructions.

STEP 3

Install the second row directly on top of the first and ensure all the Lock Latches are proper engaged.

STEP 4

Install tie wire per the "Engineered & Approved Fence Connection Types" at the locations shown in the illustration to the left. Each Speed Fence should be tied to each post.

ALWAYS REFER TO GENERAL SAFETY NOTES BEFORE INSTALLATION

KF542

WEIGHT: 24.1 lbs / 11 kg

WIDTH: 4'9" / 1450 mm

HEIGHT: 42" / 1070 mm

KF9642

WEIGHT: 45 lbs / 20.5 kg

WIDTH: 9'6" / 2900 mm

HEIGHT: 42" / 1070 mm

SPEED  **EDGE**

FOR TECHNICAL ASSISTANCE:

info@speededge.ca

905-857-9888

speededge.ca

INSTALLATION

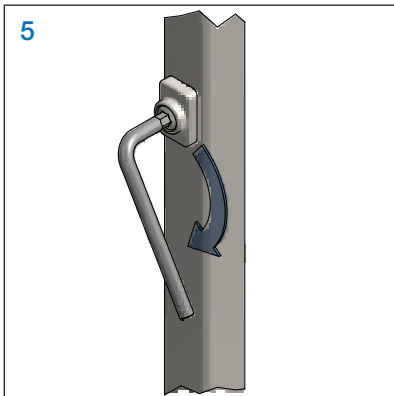
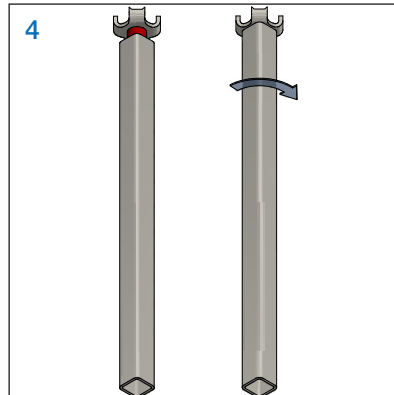
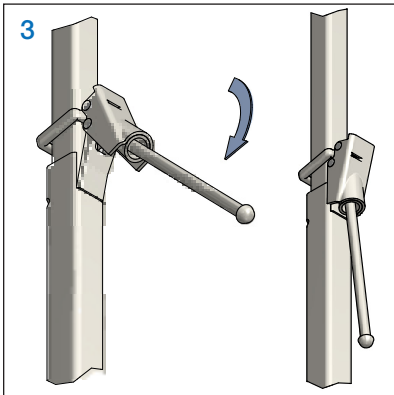
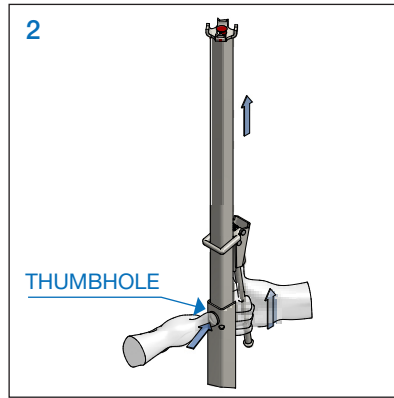
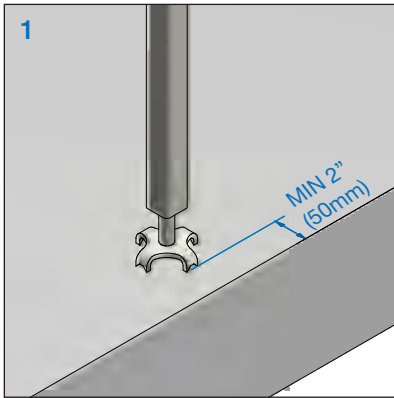

When all the steps are completed, the Speed Post is ready for the Speed Fence or temporary guardrail to be installed

Maximum spacing of Speed Posts not to exceed 9' (2743 mm)

WEIGHT: 24.5 lbs / 11.1 kg
MAX HEIGHT: 10'8" / 3251 mm
CLOSED HEIGHT: 6'6" / 1981 mm

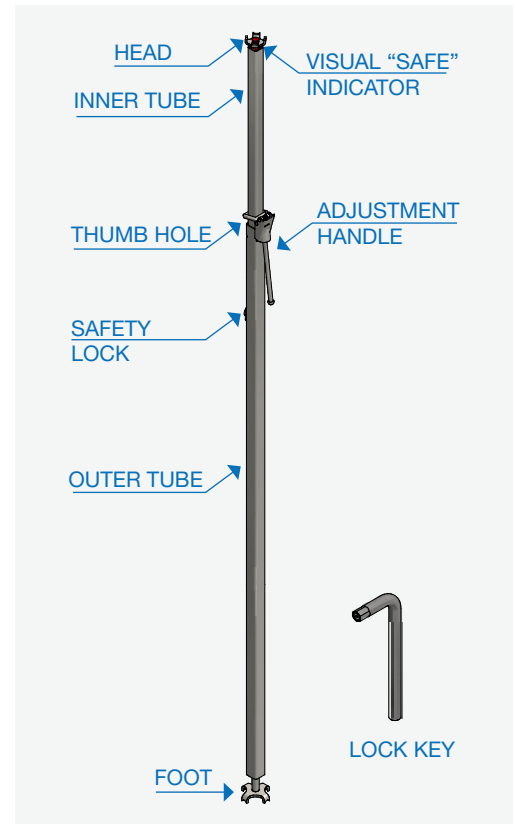

STEP 1

Ensure bottom foot is fully threaded in. Locate Speed Post and ensure it is visually plumb. Minimum edge distance: 2" (50 mm)

STEP 2

Raise the Speed Post with the handle until the head contacts the slab above. Press thumb firmly in the thumb hole to hold Inner Tube in place.

STEP 3

Slide the handle down until the ring sits on top of the outer tube.

Place the bottom end of the handle tongue in the slot of the outer tube.

Push the handle down to engage and lock the Speed Post.

STEP 4

Verify there is no red showing at the visual "safe" indicator. Turn the Speed post counterclockwise until the red is no longer visible.

STEP 5

To prevent tampering, use the Safety Lock Key by inserting the lock key and turning clockwise until tight.

DISMANTLING

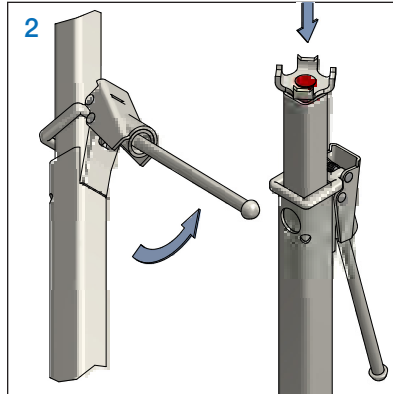
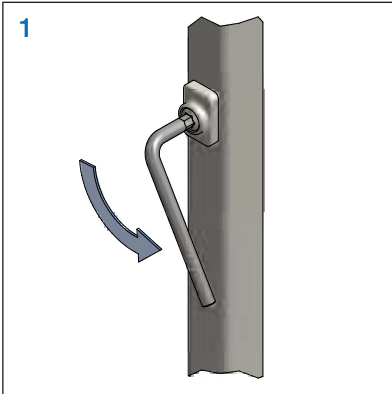

STEP 1

Remove the Speed Fence or temporary guardrail from the Speed Post.

Unlock the post with the Safety Lock Key by turning counterclockwise if necessary.

STEP 2

Hold ONLY the outer tube and lift the handle. Release the ring by pushing the handle toward the inner tube – shake the handle if necessary to release the ring.

Allow the inner tube to retract fully and place the handle down before storing.

ALWAYS REFER TO GENERAL SAFETY NOTES BEFORE INSTALLATION

SPEED  **EDGE**

FOR TECHNICAL ASSISTANCE:

info@speededge.ca

905-857-9888

speededge.ca

INSTALLATION

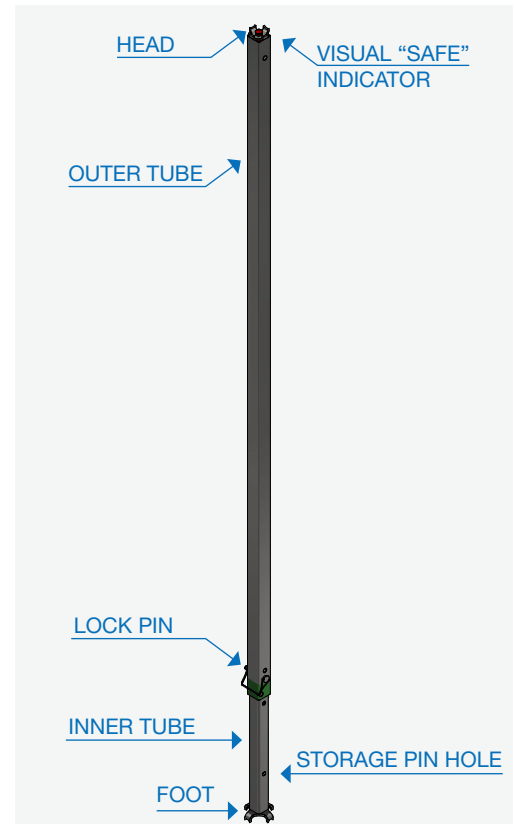
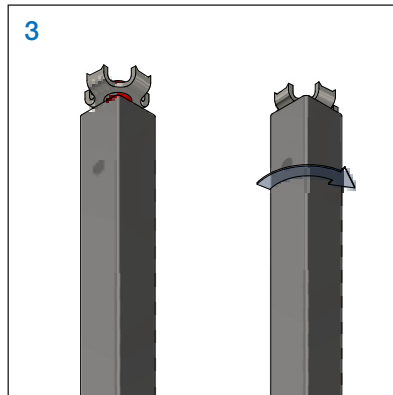
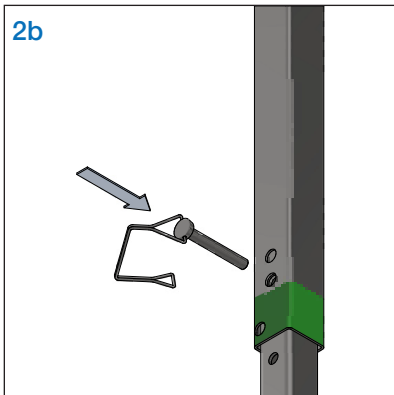
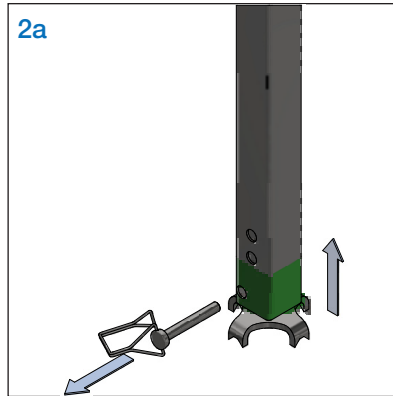
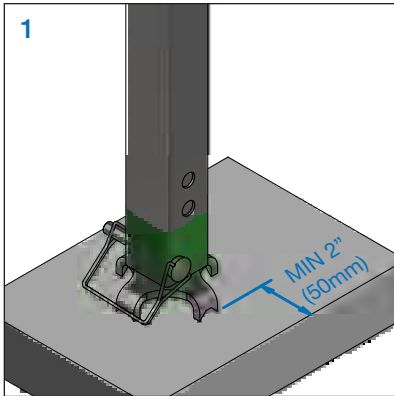

When all the steps are completed, the High Post is ready for the Speed Fence or temporary guardrail to be installed
 Maximum spacing of High Posts not to exceed 9' (2743 mm)

WEIGHT: 28 lbs / 12.7 kg
HEIGHT: 8'2"-13'6" / 2489-4115 mm
CLOSED HEIGHT: 7'1" / 2159 mm

STEP 1

Ensure foot is fully threaded in.
 Locate the post and ensure it is visually plumb.
 Minimum edge distance: 2" (50 mm)

STEP 2

Remove the lock pin and extend the outer tube until the head contacts the slab above.
 Install the lock pin in the closest hole.

STEP 3

Turn the post counterclockwise until it is tight and until there is no red showing at the visual "safe" indicator.

DISMANTLING

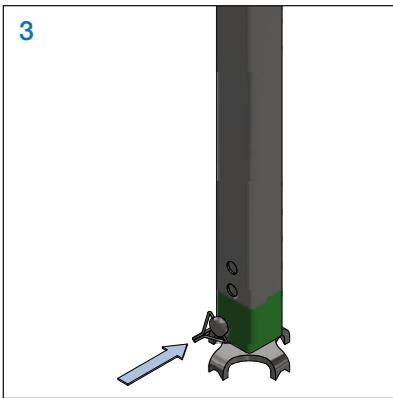
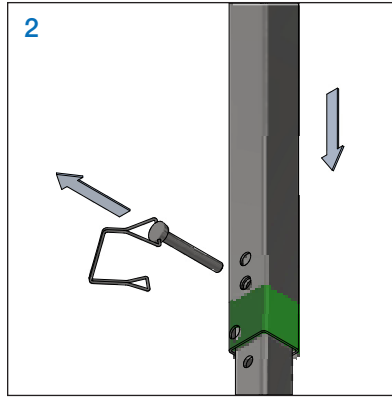
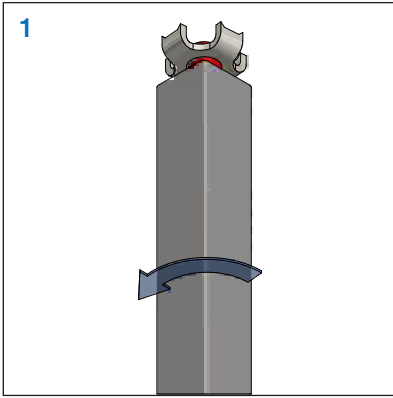

STEP 1

Turn the post clockwise until the head is clear of the slab above.

STEP 2

Remove the lock pin and lower the outer tube to its lowest position.

STEP 3

Install the lock pin in the "Storage Pin Hole" and ensure foot is fully threaded in.

ALWAYS REFER TO GENERAL SAFETY NOTES BEFORE INSTALLATION

SPEED  **EDGE**

FOR TECHNICAL ASSISTANCE:

info@speededge.ca

905-857-9888

speededge.ca

INSTALLATION

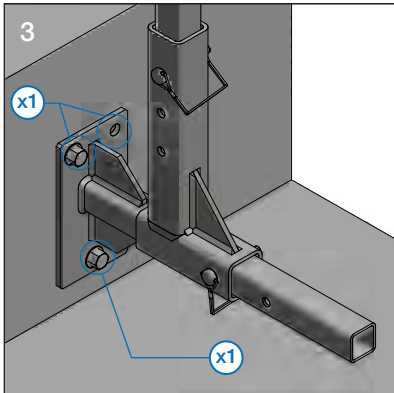
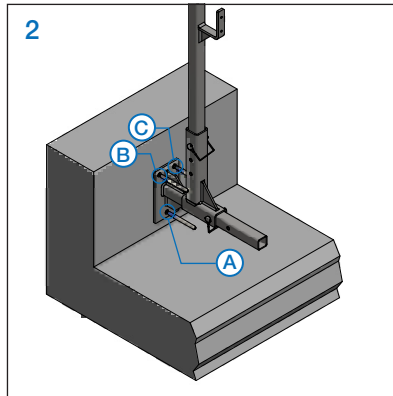
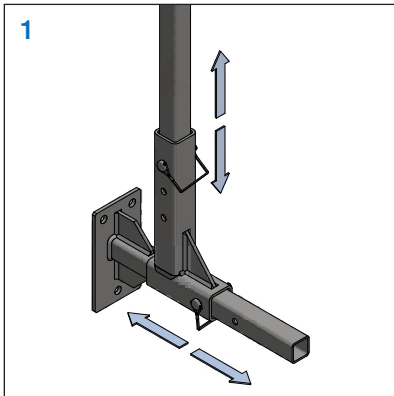

ANCHOR OPTIONS:

- Hilti Quick Bolt 3
- Red Head True Bolt
- Powers Power Stud
- Powers Wedge Bolt

ANCHOR SIZE:

- 3/8" (9.5 mm) diameter by 3 1/2" (89 mm) long anchor with a minimum embedment of 3" (75 mm)

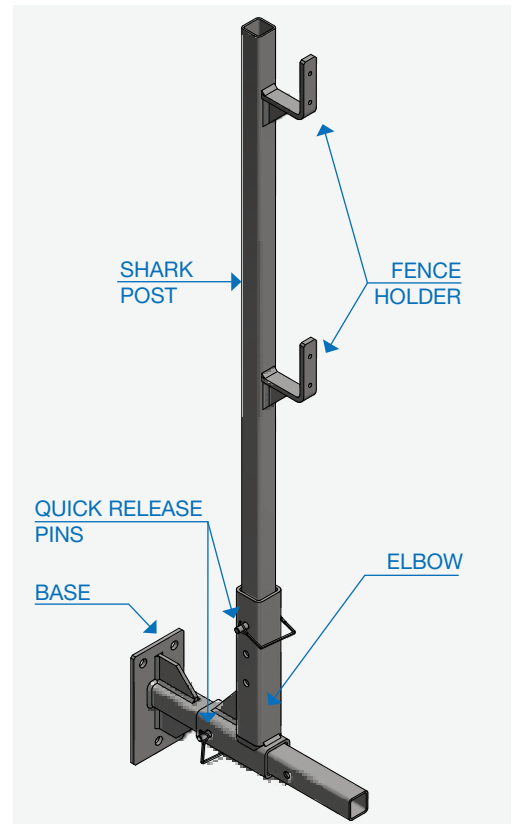

STEP 1

Adjust the elbow and Parapet Post to accommodate the geometry of the parapet. Install the quick release pins to lock the base, elbow and Parapet Post.

Minimize the gap between the parapet edge and Parapet Post.

STEP 2

Position the Parapet Post against the parapet and mark the location of (1) anchor in hole "A". Ensure the post is plumb and mark the location of (1) additional anchor in either hole "B" or "C".

STEP 3

Drill and anchor the Parapet Post with an approved anchor as noted.

RAILINGS

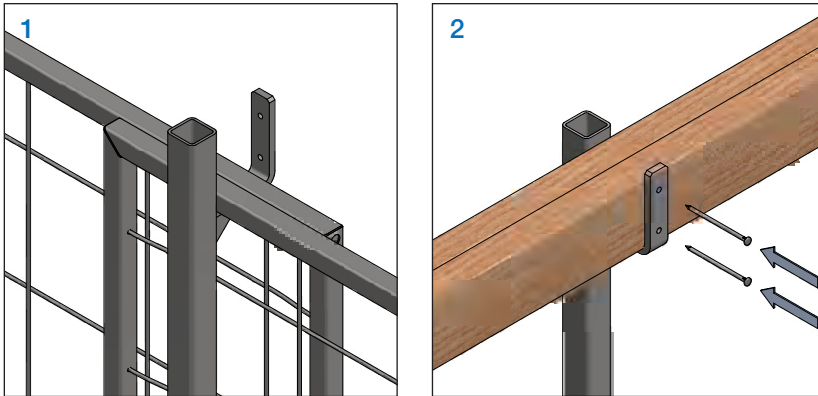

When all the steps are completed, the Parapet Post is ready for the Speed Fence or temporary guardrail to be installed
Maximum spacing of Parapet Posts not to exceed 9' (2743 mm)

WEIGHT: 28 lbs / 12.7 kg

OPTION 1

Connect the Speed Fence to the Fence Holder as per the Speed Fence installation instructions.

OPTION 2

Slide 2 x 4 (38 mm x 89 mm) lumber through the Fence Holders and nail with (2) 2 ½" long common nails.

ALWAYS REFER TO GENERAL SAFETY NOTES BEFORE INSTALLATION

SPEED  **EDGE**

FOR TECHNICAL ASSISTANCE:

info@speededge.ca
905-857-9888
speededge.ca

INSTALLATION

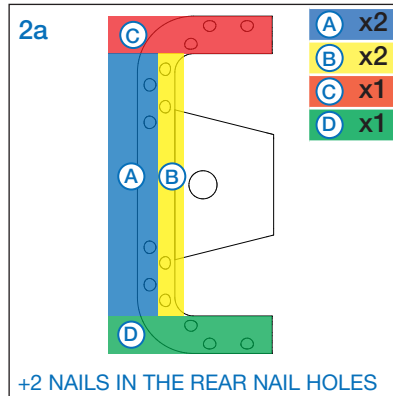
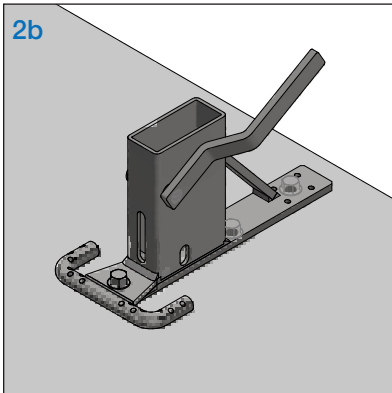
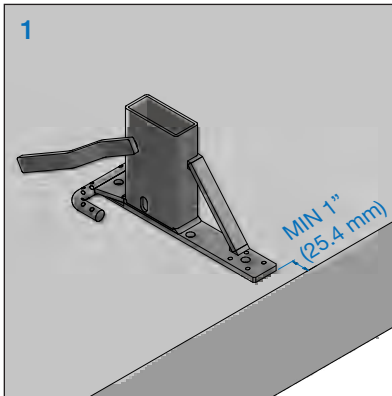

ANCHOR OPTIONS:

- Hilti Quick Bolt 3
- Red Head True Bolt
- Powers Power Stud
- Powers Wedge Bolt

ANCHOR SIZE:

- 3/8" (9.5 mm) diameter by 3 1/2" (89 mm) long anchor with a minimum embedment of 3" (75 mm)

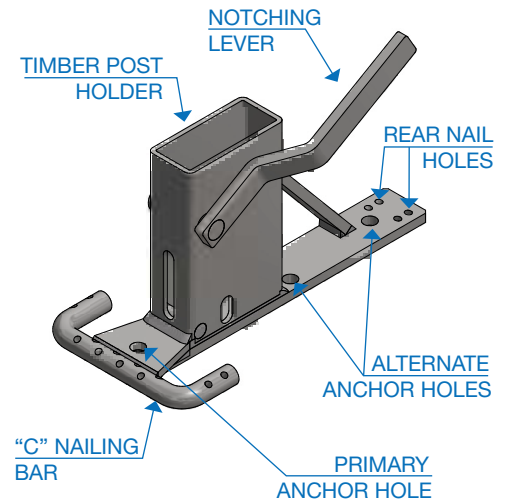

STEP 1

Orient the Shark Base with the "C" Nailing Bar facing away from the leading edge. Ensure the Shark Base is located at least 1" (25.4 mm) away from the leading edge.

STEP 2

2A) FASTENING TO 3/4" (19.1 mm) PLYWOOD:

Follow the nailing diagram above for placement and quantity of nails.

Nail a minimum of two (2) 3 1/2" common nails into the front of the "C" Nailing Bar (Zone A - Blue).

Nail a minimum of two (2) 3 1/2" common nails into the back of the "C" Nailing Bar (Zone B - Yellow)

Nail a minimum of one (1) 3 1/2" common nail into each of the sides of the "C" Nailing Bar (Zone C & D - Red & Green)

Nail a minimum of two (2) 3 1/2" common nails into the Rear Nail Holes.

(Alternatively, 3 1/2" common nails can be substituted for #8 x 2" long wood screws; quantity and placement remain the same)

2B) FASTENING TO CONCRETE:

Mark the anchor hole locations.

One (1) anchor required when using the primary anchor hole.

Two (2) anchors required when using the alternate anchor holes.

Drill and anchor the Shark Base with approved anchor(s) as noted.

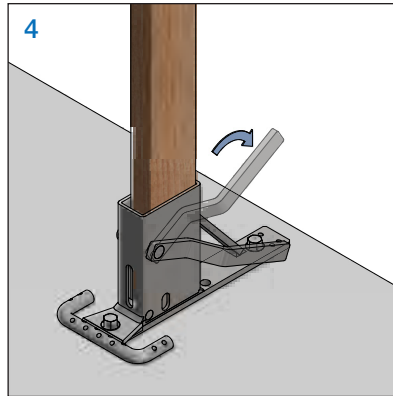
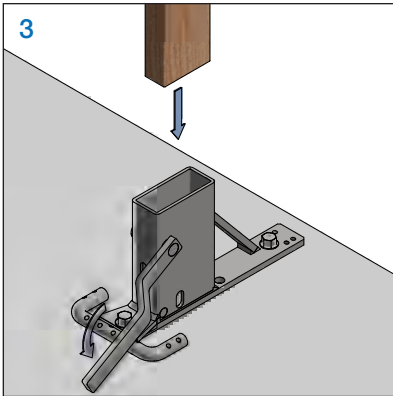

STEP 1

Open the notching lever bar by rotating it until it is facing the "C" Nailing Bar and insert a 2 x 4 (38 mm x 89 mm) lumber post into the post holder.

STEP 2

Close the notching lever by rotating it until it is horizontal and pointing towards the leading edge.

Confirm the lumber is locked in place before installing the Speed Fence or temporary guardrail.

When all the steps are completed, the Shark Base is ready for the Speed Fence or temporary guardrail to be installed

Maximum spacing of Shark Base not to exceed 9' (2743 mm)

WEIGHT: 10 lbs / 4.4 kg

ALWAYS REFER TO GENERAL SAFETY NOTES BEFORE INSTALLATION



FOR TECHNICAL ASSISTANCE:

info@speededge.ca

905-857-9888

speededge.ca

INSTALLATION

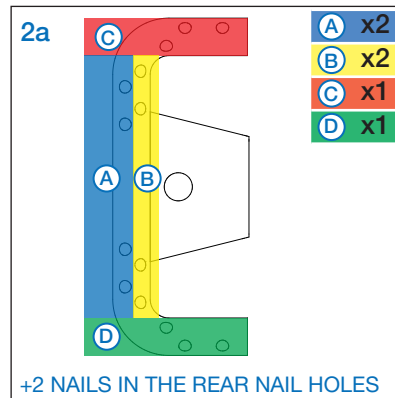
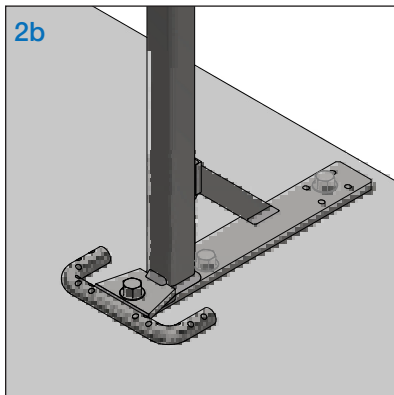
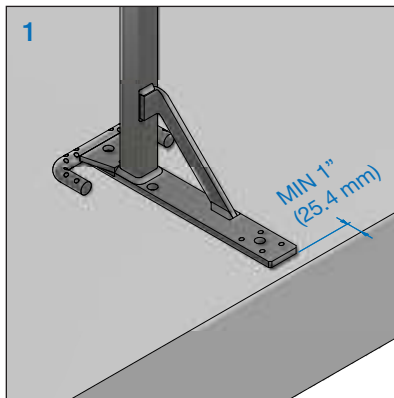

ANCHOR OPTIONS:

- Hilti Quick Bolt 3
- Red Head True Bolt
- Powers Power Stud
- Powers Wedge Bolt

ANCHOR SIZE:

- 3/8" (9.5 mm) diameter by 3 1/2" (89 mm) long anchor with a minimum embedment of 3" (75 mm)

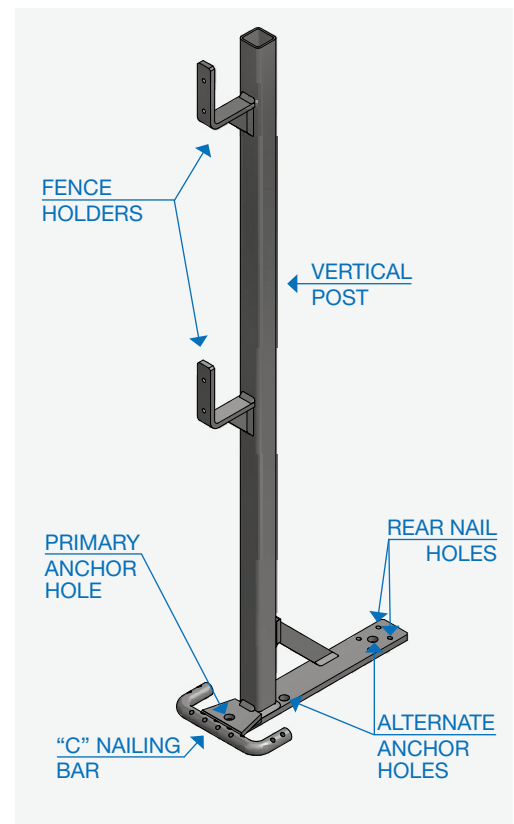

STEP 1

Orient the Shark Stand with the "C" Nailing Bar facing away from the leading edge. Ensure the Shark Stand is located at least 1" (25.4 mm) away from the leading edge.

STEP 2

2A) FASTENING TO 3/4" (19.1 mm) PLYWOOD:

Follow the nailing diagram above for placement and quantity of nails.

Nail a minimum of two (2) 3 1/2" common nails into the front of the "C" Nailing Bar (Zone A - Blue).

Nail a minimum of two (2) 3 1/2" common nails into the back of the "C" Nailing Bar (Zone B - Yellow)

Nail a minimum of one (1) 3 1/2" common nail into each of the sides of the "C" Nailing Bar (Zone C & D - Red & Green)

Nail a minimum of two (2) 3 1/2" common nails into the Rear Nail Holes.

(Alternatively, 3 1/2" common nails can be substituted for #8 x 2" long wood screws; quantity and placement remain the same)

2B) FASTENING TO CONCRETE:

Mark the anchor hole locations.

One (1) anchor required when using the primary anchor hole

Two (2) anchors required when using the alternate anchor holes.

Drill and anchor the Shark Stand with approved anchor(s) as noted.

RAILINGS

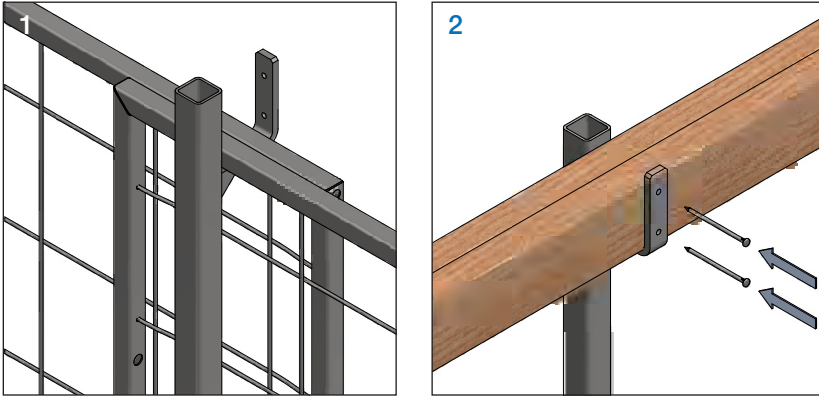

STEP 1

Connect the Speed Fence to the Fence Holder as per the Speed Fence installation instructions.

STEP 2

Slide 2 x 4 (38 mm x 89 mm) lumber through the Fence Holders and nail with (2) 2 1/2" long common nails.

When all the steps are completed, the Shark Stand is ready for the Speed Fence or temporary guardrail to be installed

Maximum spacing of Shark Stand not to exceed 9' (2743 mm)

WEIGHT: 15 lbs / 6.7 kg

ALWAYS REFER TO GENERAL SAFETY NOTES BEFORE INSTALLATION

SPEED  **EDGE**

FOR TECHNICAL ASSISTANCE:

info@speededge.ca

905-857-9888

speededge.ca

INSTALLATION

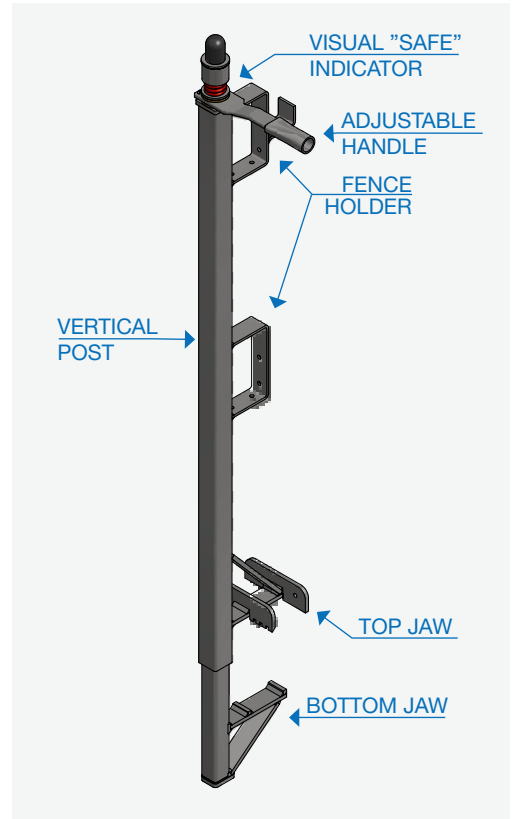
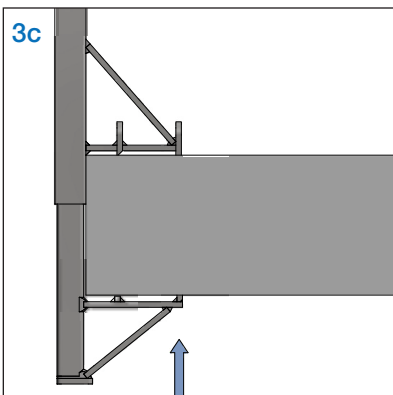
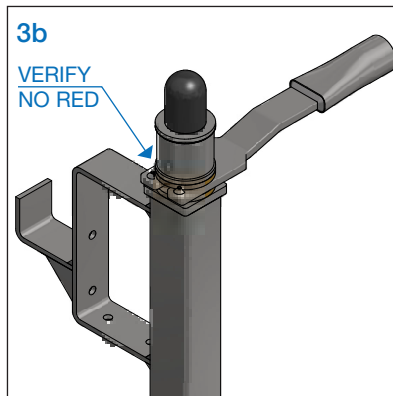
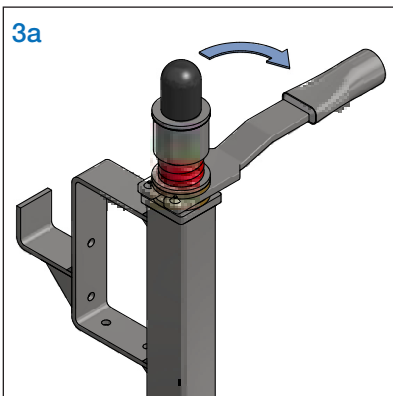
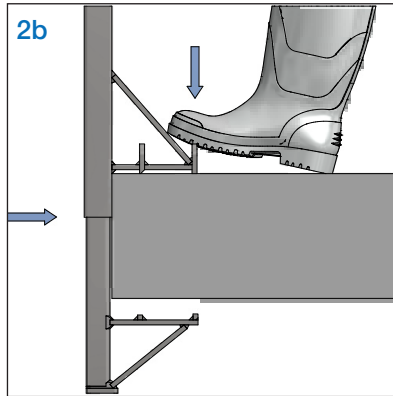
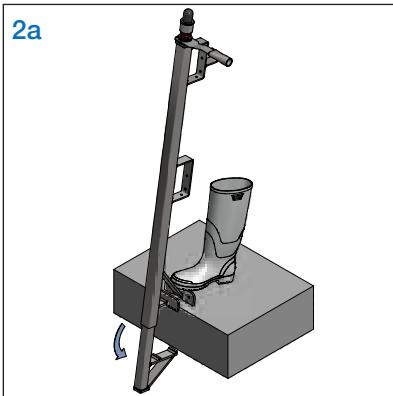
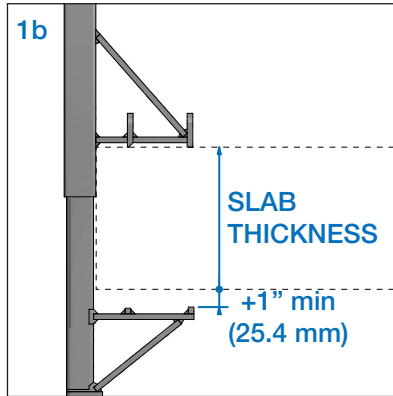
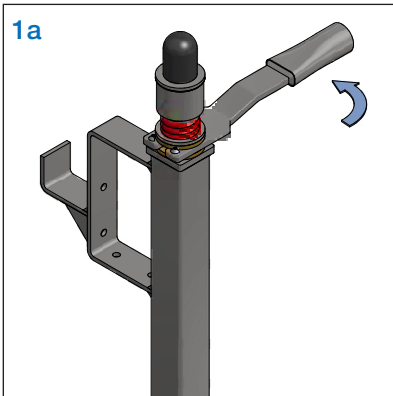

STEP 1

Turn the adjustment handle counterclockwise to open the jaw. Set the jaw opening to slab thickness + 1" (24.5 mm).

STEP 2

Position the slab grab with the vertical post against the slab edge. Step on the top jaw and rotate until vertical post is plumb and flush with the full face of the slab edge.

STEP 3

Tighten the jaw to the slab turning the handle clockwise until the visual indicator has no visible red.

RAILINGS

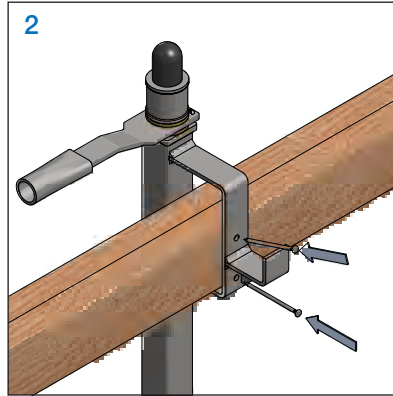
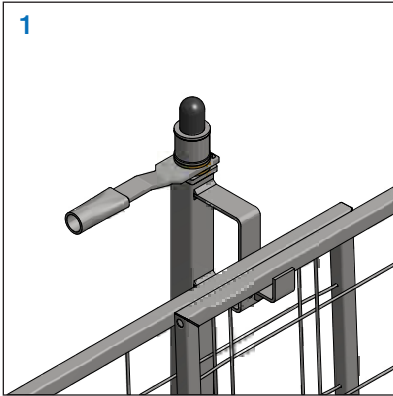

STEP 1

Connect the Speed Fence to the Guard Holder as per the Speed Fence installation instructions.

STEP 2

Slide 2 x 4 (38 mm x 89 mm) lumber through the Guard Holders and nail with (2) 3" long common nails.

When all the steps are completed, the Slab Grab is ready for the Speed Fence or temporary guardrail to be installed

Maximum spacing of Slab Grab not to exceed 9' (2743 mm)

WEIGHT: 32 lbs / 14.5 kg

SLAB THICKNESS:

MIN 3" / 76 mm; MAX 26" / 660 mm

ALWAYS REFER TO GENERAL SAFETY NOTES BEFORE INSTALLATION

SPEED  **EDGE**

FOR TECHNICAL ASSISTANCE:

info@speededge.ca

905-857-9888

speededge.ca

INSTALLATION

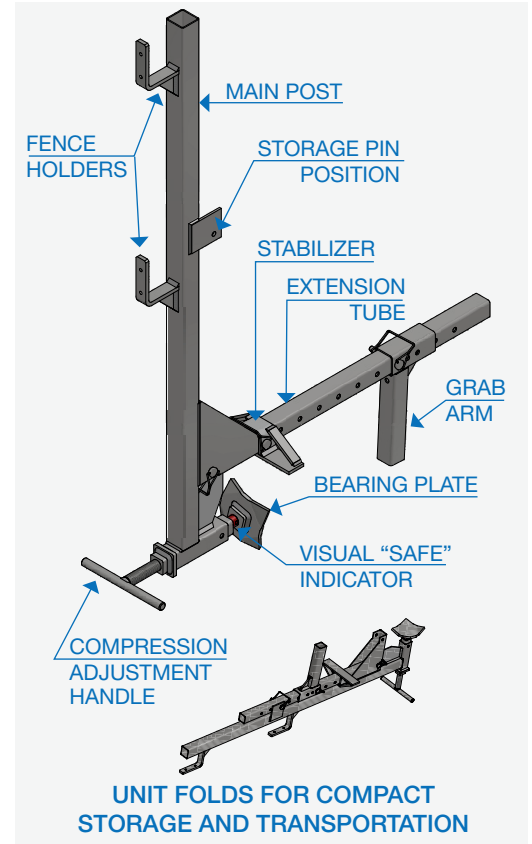
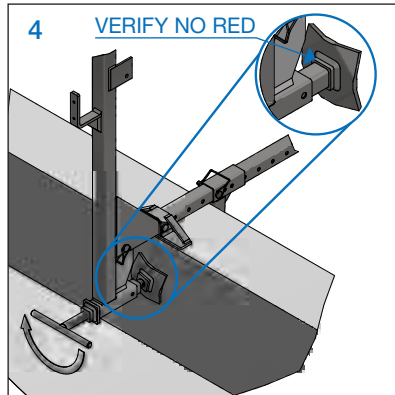
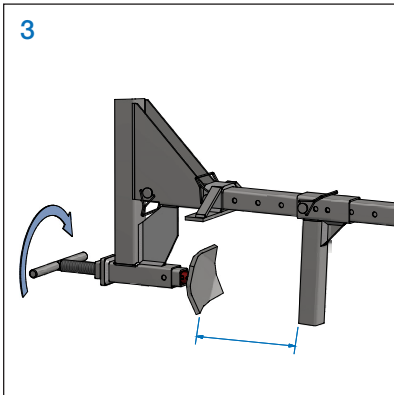
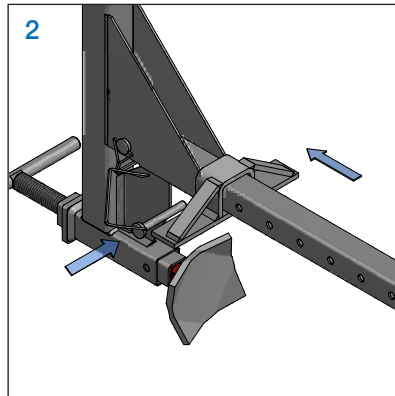
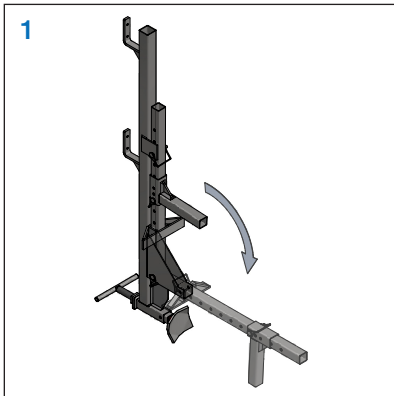

STEP 1

Remove the spring locking pin from the Storage Position and rotate the Extension Tube down until it is fully open.

STEP 2

Slide the Stabilizer into the locked position and insert the spring locking pin to secure in place.

STEP 3

Turn the Compression Adjustment Handle counterclockwise to retract the Bearing Plate fully and adjust the Grab Arm to the nearest position greater than the curb thickness.

STEP 4

Position the Curb Grab over the curb with the stabilizer resting flush to the top of the curb. Hold the Curb Grab plumb and turn the compression adjustment handle clockwise until the bearing plate is tight to the face of the curb. Verify there is no red showing at the visual "safe" indicator. Turn the compression adjustment handle clockwise until the red is no longer visible.

RAILINGS

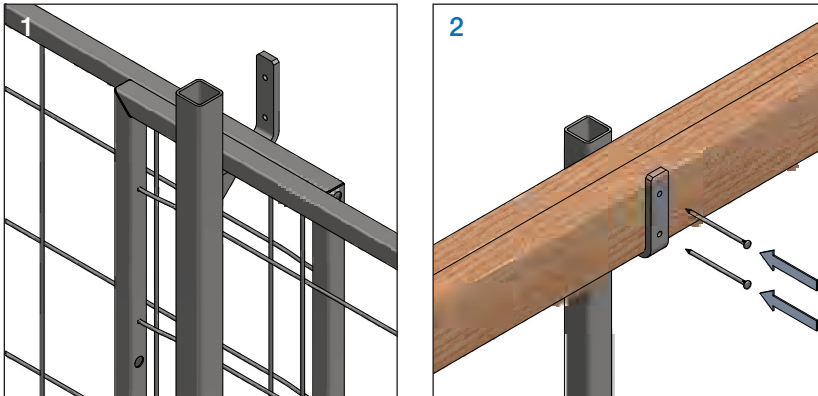

STEP 1

Connect the Speed Fence to the Fence Holder as per the Speed Fence installation instructions.

STEP 2

Slide 2 x 4 (38 mm x 89 mm) lumber through the Fence Holders and nail with (2) 2 1/2" long common nails.

When all the steps are completed, the Curb Grab is ready for the Speed Fence or temporary guardrail to be installed

Maximum spacing of Curb Grab not to exceed 9' (2743 mm)

WEIGHT: 27 lbs / 12.2 kg
MAX CURB: 21" / 530 mm

ALWAYS REFER TO GENERAL SAFETY NOTES BEFORE INSTALLATION

SPEED  **EDGE**

FOR TECHNICAL ASSISTANCE:

info@speededge.ca
905-857-9888
speededge.ca

GROUND INSTALLATION

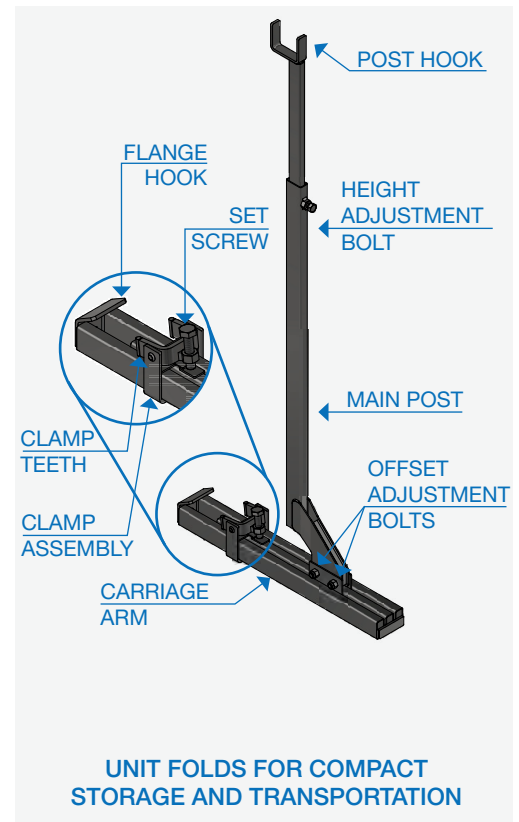
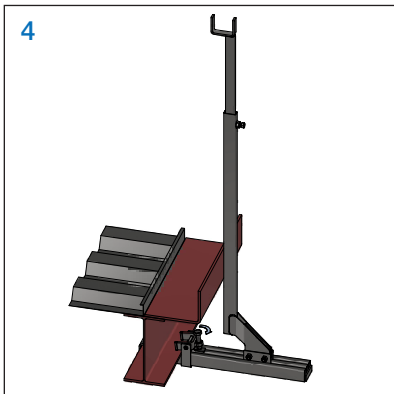
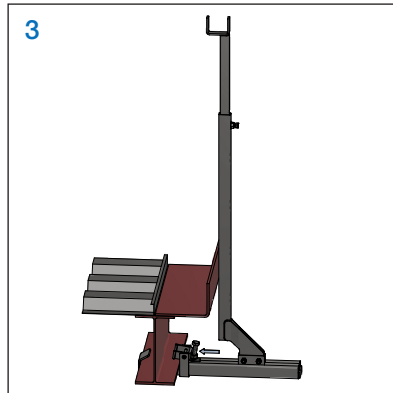
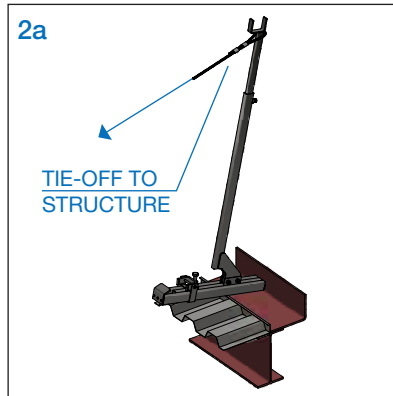
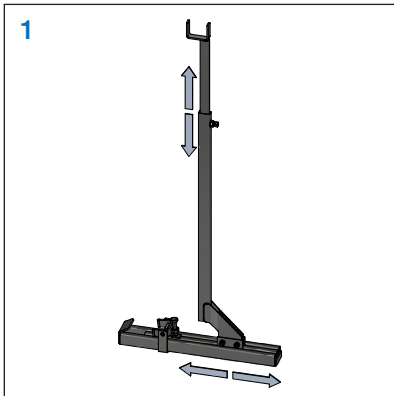

STEP 1

Adjust the post height and offset to suit the leading edge geometry. Loosen the adjustment bolts, slide the post to the desired height and offset position. Re-tighten the bolts to prevent further movement.

STEP 2

If installing the Beam Clamp at heights, ensure it is securely tethered to the existing structure.

Guide the Flange Hook onto the inside beam flange by hooking it over the flange and rotating the Beam Clamp level to secure in place.

STEP 3

Slide the Clamp Assembly until it is flush to the outer beam flange with the Clamp Teeth above the flange.

STEP 4

Tighten the Clamp Assembly Set Screw until the Clamp Teeth are firmly secured to the beam flange.

RAILINGS

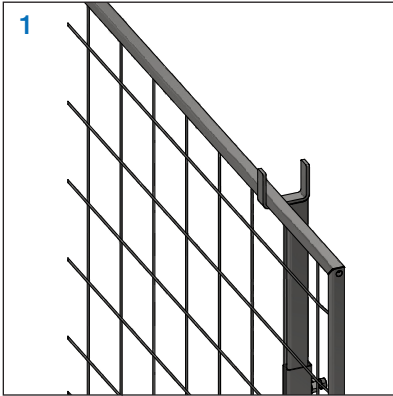

STEP 1

Connect the Speed Fence to the Guard Holder as per the Speed Fence installation instructions.

When all the steps are completed, the Beam Clamp is ready for the Speed Fence to be installed

Maximum spacing of Beam Clamps not to exceed 9' (2743 mm)

WEIGHT: 27 lbs / 12.2 kg

ALWAYS REFER TO GENERAL SAFETY NOTES BEFORE INSTALLATION

SPEED  **EDGE**

FOR TECHNICAL ASSISTANCE:

info@speededge.ca

905-857-9888

speededge.ca